

## ADJUSTING UNIT VEN 45X90 H WITH OUT CLAMPING DEVICE

Code: 280185/0

Linear unit VEN 45x90 H with and adjustment allows quick and precise alignment of conveyors, feeders, and other adjustable devices.

[Link to the product →](#)

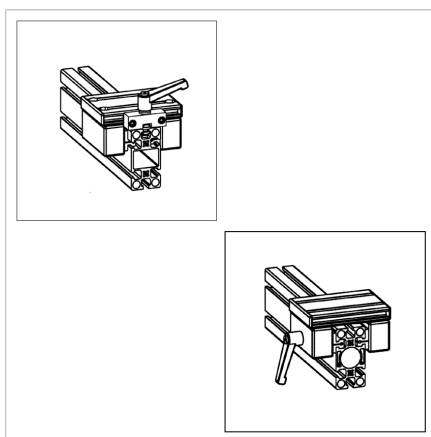
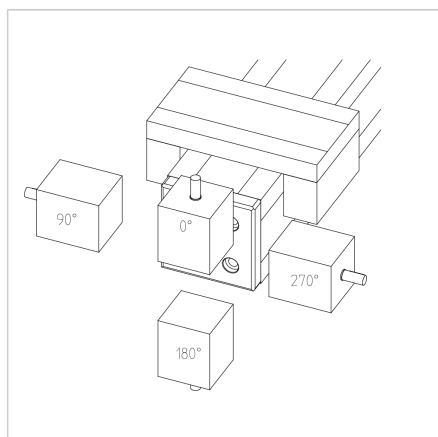
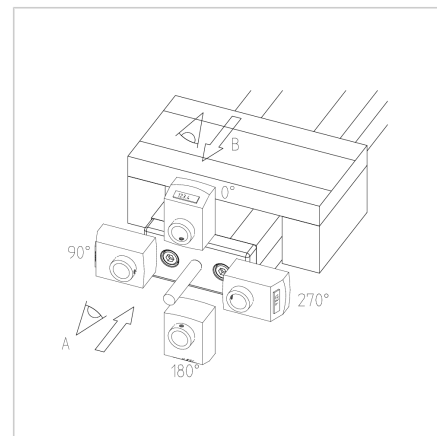
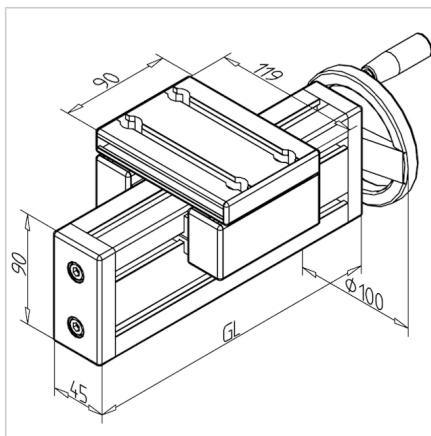
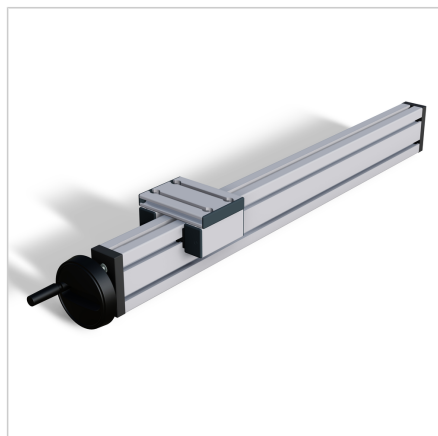

### Technical data/items supplied

- Aluminium, anodized E6/EV1
- Slide plate of profile 19 x 90
- Spindle 16 x 4
- Basic length (GL) 120 mm (0 mm stroke)
- **Please indicate desired length of stroke**
- Weight = (basic weight) 1.97 kg
- Extra weight = 0.49 kg/100mm stroke

### Applications

- Adjustment of conveyors
- Adjustment of feeders
- Adjustable devices

### Other versions

- Slide plate made of profile 32 x 180
- Deviating wagon length
- Digital display
- Angular drive
- Options:
  - With carriage clamp up **part no.** [280185/1](#)
  - With carriage clamping laterally **part no.** [280185/2](#)
- Longer length possible if needed