

DRAWER FLOOR CABINET 50/100/150

Code: 320812/2

Tool drawer cabinet 50/100/150 is ideal for an organized workstation with quick access to all tools.

[Link to the product →](#)

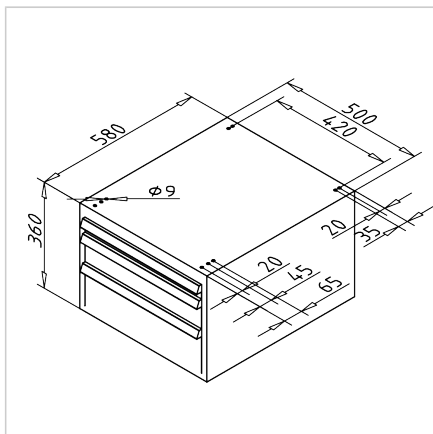

Technical data/items supplied

- Steel, lacquered
- With fastening material steel, zinc plated
- Cylinder lock with 2 keys, center locking for all drawers
- Individual drawer locking
- 1 drawer H = 50 mm, 1 drawer H = 100 mm, 1 drawer H = 150 mm, with perforated bottom
- Large handle bar with label adapter
- Can be pulled out up to 80 %
- Drawer inside W = 425 mm T = 550 mm, effective height = H-10 mm
- Max. load capacity per compartment 35kg
- Max. load capacity per cabinet: 200 kg
- **Please specify the desired color(s) for carcasses and drawers!**
- The following colours can be delivered without additional price:
 - grey-green HF 0001 (similar to RAL 6000)
 - reseda green RAL 6011
 - light grey RAL 7035
 - light blue RAL 5012
 - ruby red RAL 3003
 - water blue RAL 5021
 - anthracite RAL 7016
 - red-orange RAL 2001
 - brilliant blue RAL 5007
 - silver aluminium similar to RAL 9006
- Weight = 33.000 kg/piece

Assembly

- Use fastening kit to fasten to base frame
- Alternatively attach with mounting set **part no. 320806/0** to strut profiles of the base frame