

## DRILLING JIG FOR MITRE-CONNECTOR N 45 (GVB-N45)

Code: 261060/0

Drilling jig for mitre connector N45 provides precise hole drilling, easy positioning, and quick preparation of aluminum profiles for assembly.

[Link to the product →](#)

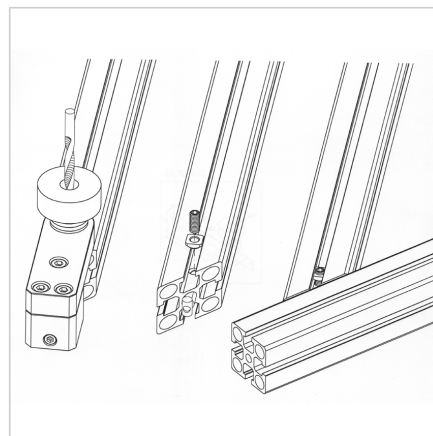
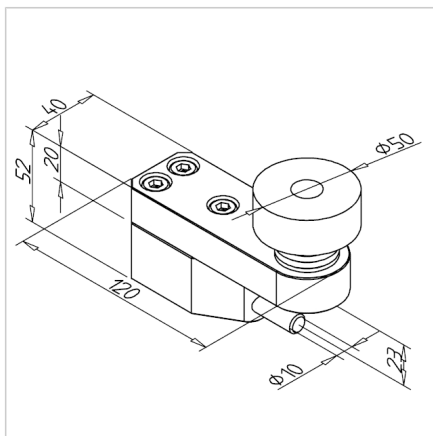
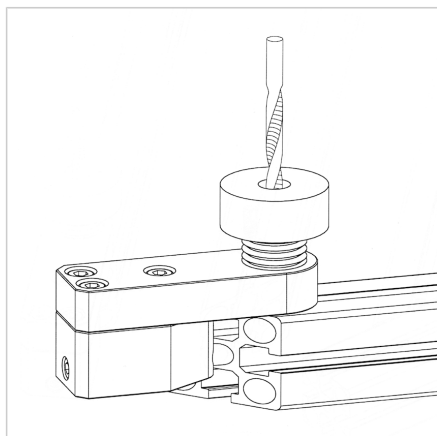

### Technical data/items supplied

- Material: Aluminium
- Centering pin: steel
- Fixation screw: Plastic with steel bore bushing
- Weight = 0.556 kg/piece

### Applications

- Production of the fastening bore for miter connectors N45 depending on the miter angle.
- Fitting for all profiles of profile series 45

### Assembly

- Cut profile in desired angle, rebore the center-bore  $\text{Ø} 10,1$  mm with twist drill **part no. 261816/0**
- Insert the plug gauge until the stop, tighten the plastic locking screw
- Insert bore  $\text{Ø} 8.0$  mm into profile at corresponding depth through drill bush
- Insert mitre-connector