

DRIVE DRUM 45ST L , PLUG-ON MOTOR D16 L (BELT WIDTH) = MM

Code: 295023/1

[Link to the product →](#)

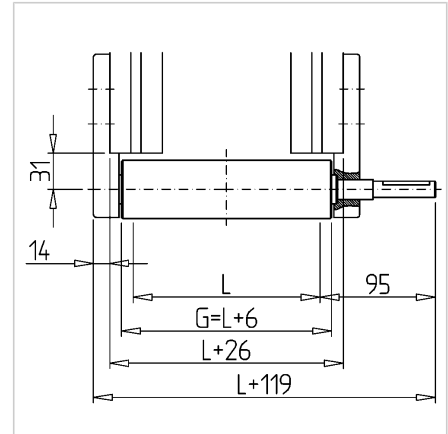
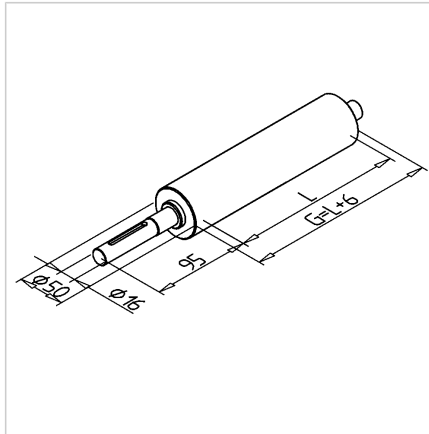

Technical data/items supplied

- Stainless steel
- Turned round
- Shaft pin $\varnothing 16$ mm, drive side machined for mounting of plug-on motor
- **Please specify dimension L (belt width)**
- **Attention: L is not the external dimensions(G) of the conveyor $\varnothing 50$**
- Weight = (basic weight) approx. 0.3 kg
- Extra weight = 1.541 kg/100mm belt width

Applications

- Suitable for MiniTec motor with torque arm of series 45
- On request we can deliver the conveyor with mounted ball bearings. The bearings are gentle on material, hot pressed. Please additionally following **part no.** 21.0900/0 order.

Assembly

- Belt driving cylinder in conveyor bearing for slip-on motor e.g. **part no.** 210993/1 insert
- On the opposite side conveyor bearing e.g. **part no.** 210993/0 mount