

## DRUM BEARING 45 H FOR DRIVE WITH NON-CORROSIVE BEARING AND SCREWS

Code: 210993/6

[Link to the product →](#)

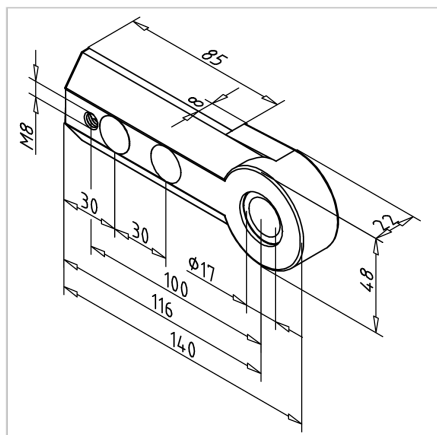

### Technical data/items supplied

- Aluminium, Pressure die-casting, powder-coated, grey
- With bore for drive adapter
- Self-aligning bearing with bore  $\varnothing$  17 mm, sealed on both sides
- Fixing material and ball bearing are stainless
- Weight = 0.287 kg/piece

### Applications

- Reversing unit and belt driving cylinder of conveyor belts
- Attachment of plug in motors or chain wheels to through shaft up to max.  $\varnothing$  17 mm
- Can be retrofitted with intervention protection **part no.** [210909/9](#)

### Assembly

- Pre-mount conveyor bearing to profile end
- When using swivel plates **part no.** [295001/0](#) for mounting the substructure, these serve as counter-bearings for clamping, otherwise use multi-block or mounting angle bracket
- Tighten the conveyor belt by unscrewing the set screw, if necessary reset the tool
- Firmly tighten the conveyor bearing (recommended tightening torque: 25 Nm)