

DRUM BEARING 45

Code: 210993/0

Conveyor end ensures reliable belt drive, smooth material flow, and added protection for a safe working environment.

[Link to the product →](#)

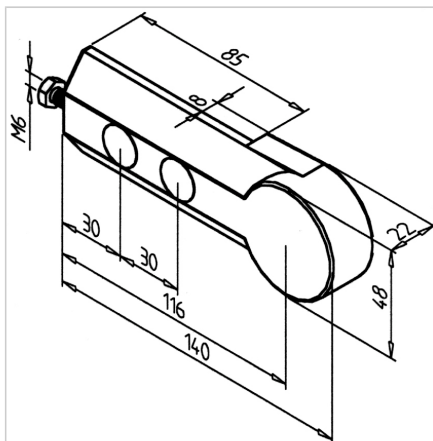

Technical data/items supplied

- Aluminium, Pressure die-casting, powder-coated, grey
- Self-aligning bearing with bore \varnothing 17 mm, sealed on both sides
- Version in aluminium GD, with stainless bearing and fastening kit, conveyor bearing 45 H, **part no.** [210993/5](#)
- Stainless version, conveyor bearing 45 VA, **part no.** [210979/0](#)
- Weight = 0.287 kg/piece

Applications

- Reversing unit and belt driving cylinder of conveyor belts
- Can be retrofitted with intervention protection **part no.** [210909/9](#)

Assembly

- Pre-mount conveyor bearing to profile end
- When using swivel plates **part no.** [295001/0](#) for mounting the substructure, these serve as counter-bearings for clamping, otherwise use multi-block or mounting angle bracket
- Tighten the conveyor belt by unscrewing the set screw, if necessary reset the tool
- Firmly tighten the conveyor bearing (recommended tightening torque: 25 Nm)