

FASTENING KIT LRE

Code: 280022/0

LRE fastening kit for easy and reliable mounting of components on linear guides.

[Link to the product →](#)

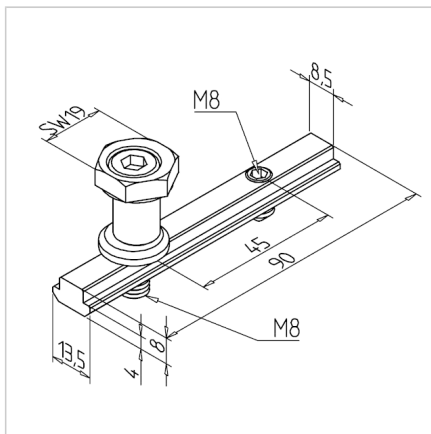
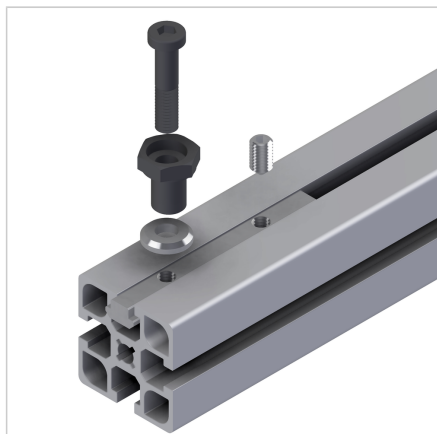

Technical data/items supplied

- 1 T-slot bar, steel, zinc plated with set screw
- Eccentric bushing, steel, black bronze finish
- Bolt M8 concentric, steel, black bronze finish
- Spacer 3.5 mm, polished, steel, black bronze finish
- Stainless version **part no. 280022/1**
- Weight = 0.100 kg/piece

Applications

- MiniTec linear guides LR 12
- Concentric attachment of ball bearings LR 12

Assembly

- Fit the clamping strip similar to LRK
- Insert bolt M8 into the eccentric bushing pre-installed in the bearing bore and place the spacer washer. Pre-tighten the bolt with the Allen wrench SW4 onto the clamping bar
- Adjust bush with ring spanner width 19 mm (turn for freedom from clearance with 0,9 - 1 Nm) and fix bolt
- Recommended torque: 25 Nm