

SIDRNI VIJAK M10x100

Code: 1002206/5

Floor anchor M10 for secure attachment of profiles and frames to concrete or other solid surfaces.

[Link to the product →](#)

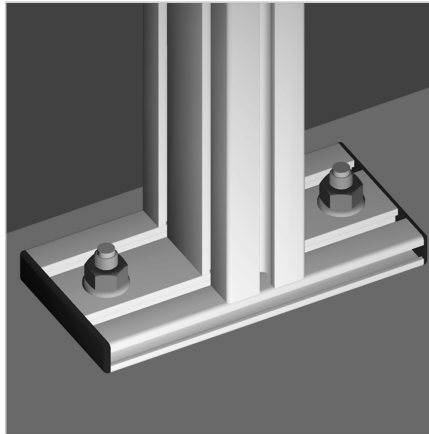

Technical data/items supplied

- Steel, galvanized
- Ø 10 mm
- Length 100 mm
- With hexagonal nut and washer
- Weight = 0.084 kg/piece

Applications

- Secure and fasten constructions in connection with the floor mounting bracket, leveling plate or stationary plate

Assembly

- Fit bore in the bottom
- Use floor anchor in connection with angle, levelling plate or floor mounting plate