

LIFT STATION

Code: 430080/0

[Link to the product →](#)

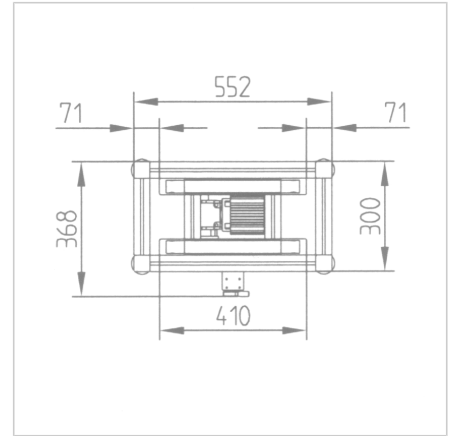
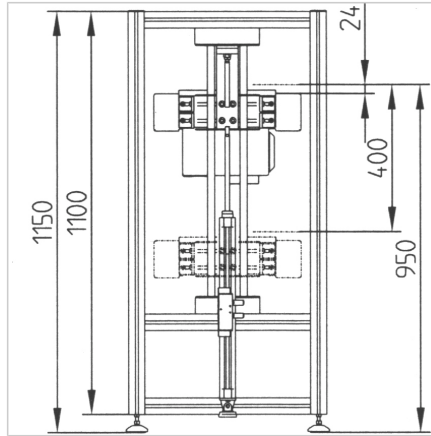
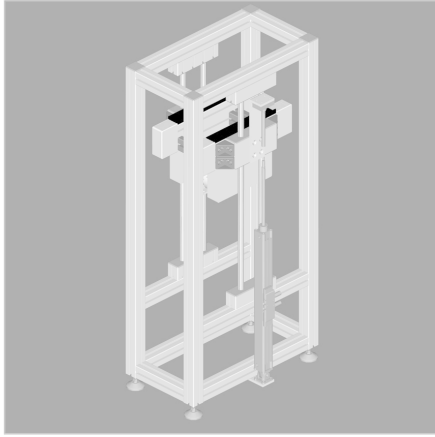

Technical data/items supplied

- Aluminium
- Ready assembled module according to customer specification
- Frame structure from construction profiles 45 x 45
- installed on lifting carriages, driven double-track line
- Lift carriage with dual-functioning pneumatic cylinder
- sturdy guidance of the lifting carriage with precision shafts \varnothing 20 mm and linear units LB series
- Lift height variable according to customer specification
- Max. load capacity: 480 N

Applications

- Production of conveyor rollers in any length for roller tracks with or without drive

Assembly

- Align lift station with transport levels