

## LINEAR MODULE LMS 90 K16X10 S1

Code: 281000/1

Linear module LMS 90 K16x10 S1

[Link to the product →](#)

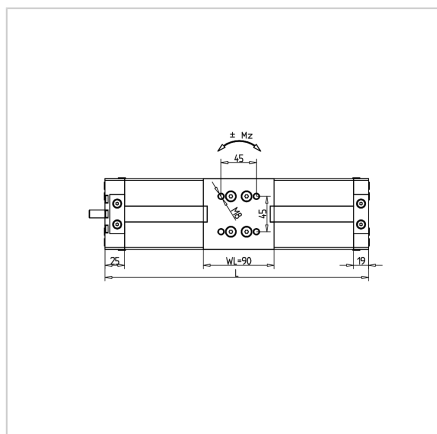
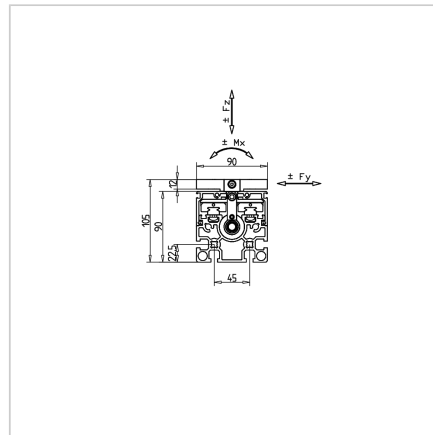
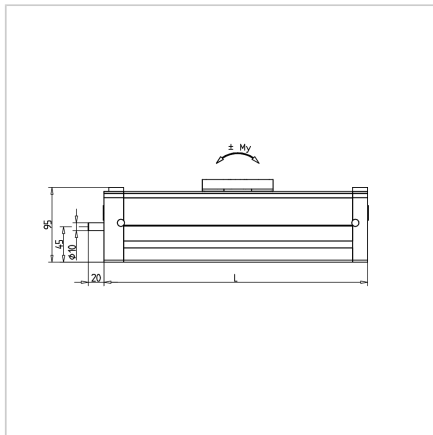

### Technical data/items supplied

- 2 rail guides with each 1 linear slide Dim. 15
- Stroke = L- 140 mm
- Stroke up to 2845 mm
- Ball screw with tolerance class T7, right
- High load-carrying rail slide with continuous lubrication
- Load rating:  
Cdyn: 7,620 N  
Cstat: 11,180 N
- Allowable static tilting moment:  
Mx: 54 Nm  
My: 54 Nm  
Mz: 54 Nm
- Max speed 30m/min

### Assembly

- Simple mounting of external switches on lateral profile grooves