

## LINEAR MODULE LMS 90 K16x10 S2

Code: 281002/1

Linear module LMS 90 K16x10 S2

[Link to the product →](#)

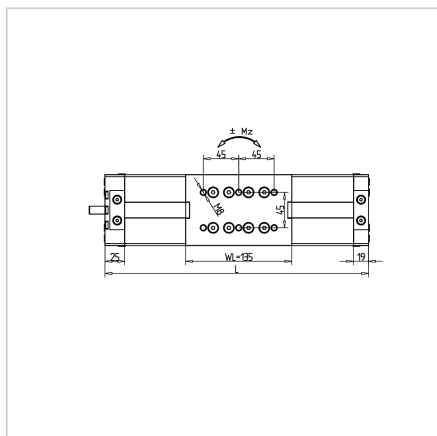
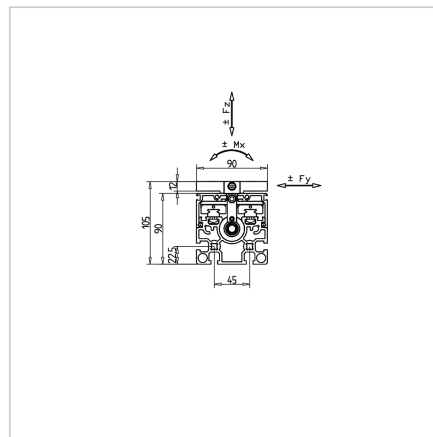
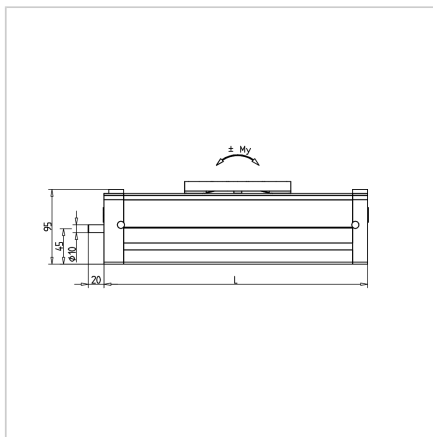

### Technical data/items supplied

- 2 rail guides with each 2 linear slide Dim. 15
- Stroke = L- 185 mm
- Travel up to 2800 mm
- High load-carrying rail slide with continuous lubrication
- Load rating:  
Cdyn: 15,240 N  
Cstat: 22,360 N
- Allowable static tilting moment:  
Mx: 108 Nm  
My: 108 Nm  
Mz: 108 Nm
- Max speed 30m/min

### Assembly

- Simple mounting of external switches on lateral profile grooves