

POSITIONER

Code: 430110/0

[Link to the product →](#)

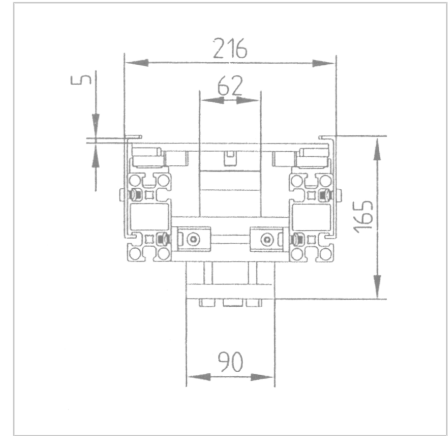
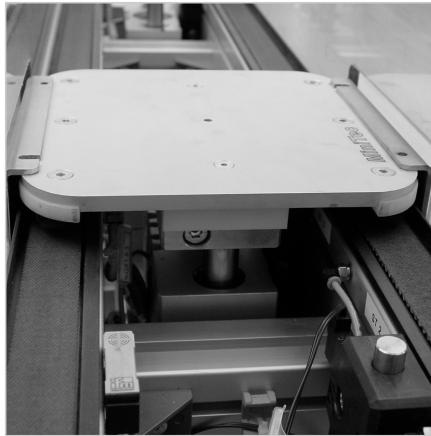
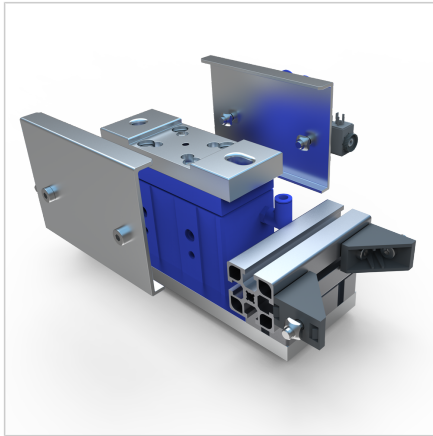

Technical data/items supplied

- Ready-to-install module with double-acting pneumatic cylinder and valve
- WT mount
- 2 override strips, galvanized steel
- Max. load capacity: 100 Kg
- Positioning accuracy: $\pm 0,03$ mm
- Lifting height over conveyor 5 mm
- Weight = 7.693 kg/piece

Applications

- Exact positioning of workpieces on the workpiece tray for processing or inspection

Assembly

- Fasten lifting unit to profile section with supplied hardware
- Screw the override strips on the outside of the track, align exactly with the positioner
- Make connection to internal compressed air supply
- Suitable stopper **part no. 431510/0** and proximity switch **part no. 430090/0**