

SLIDE LR 16 - 90

Code: 280811/0

LR 16 - 90 linear slide, designed for high precision and quiet operation of linear guides in industrial applications.

[Link to the product →](#)

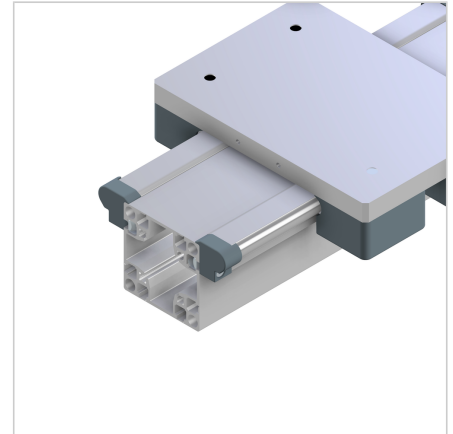
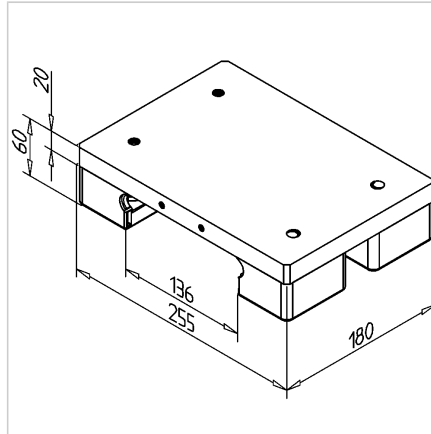
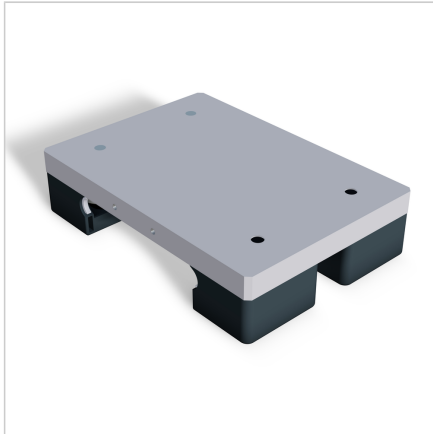

Technical data/items supplied

- Aluminium, anodized E6/EV1
- Fully mounted carriage
- 2 concentric and 2 eccentric bearing units
- Weight = 4.101 kg/piece

Applications

- 1- or multi-axis guides
- Linear robots
- Handling devices
- Measuring devices
- For rail LR16 90 and LR16 90x180 H

Assembly

- Push the trolley onto the rails, adjust for zero play with eccentric fastening set
- Install the cover and lubrication system