

## SLIDE LW 90

Code: 280092/0

LW 90 linear slide, designed for high precision and quiet operation of linear guides in industrial applications.

[Link to the product →](#)

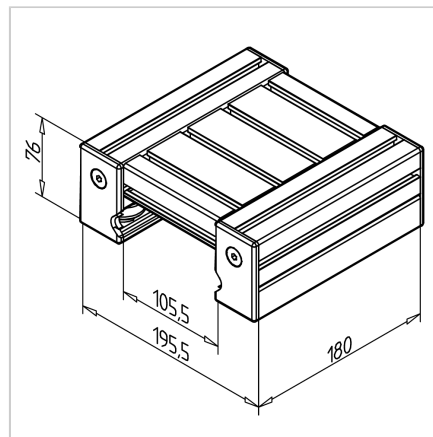
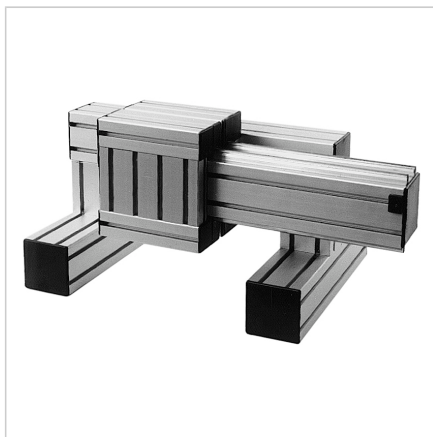

### Technical data/items supplied

- Aluminium, anodized E6/EV1
- Fully mounted carriage
- 2 concentric and 2 eccentric bearing units
- End caps LR and Cover profiles LR
- **Stainless version part no. 280092/2**
- Weight = 2.720 kg/piece

### Applications

- 1- or multi-axis guides
- Linear robots
- Handling devices
- Measuring devices
- For rails 45 x 90 F, 90 x 90, 90 x 180 H

### Assembly

- Assemble slide on rail 45 x 90 F, rail 90 or rail 90 x 180 H; adjust clearance with eccentric bush
- Install the cover and lubrication system
- Slide clamping unit **part no. 280270/0**