

SLIDE LWN 32X45-90 WITH OUT CLAMPING DEVICE

Code: 280193/0

Linear carriage LWN 32 x 45 series 90 ensures precise and smooth linear motion in aluminum profile constructions.

[Link to the product →](#)

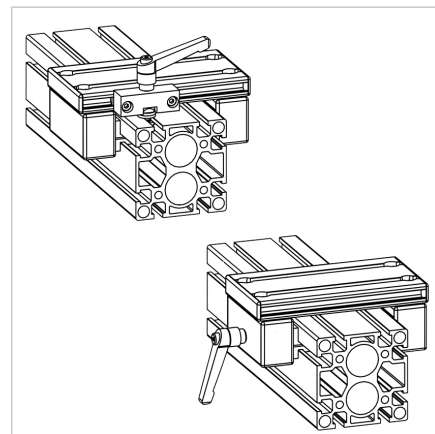
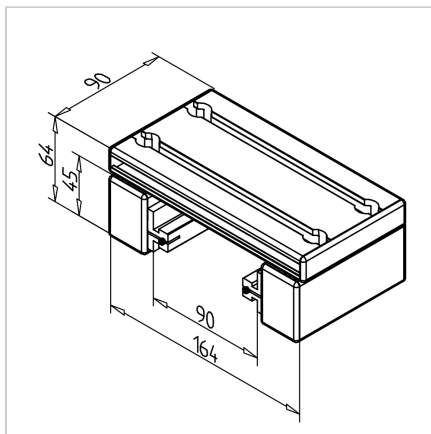
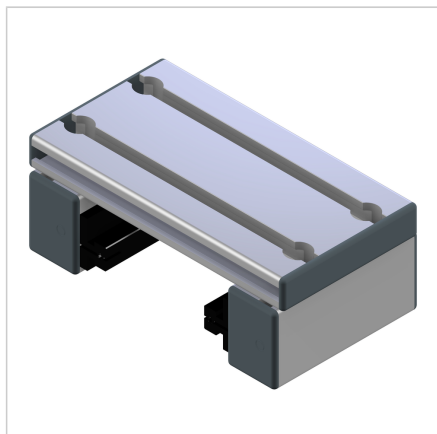

Technical data/items supplied

- Aluminium, anodized E6/EV1
- Fully mounted carriage
- 2 slide rails LN
- End caps
- Load capacity up to 450 N
- Clearance adjusted
- Weight = 0.762 kg/piece

Applications

- Simple linear guides
- Slide units

Other versions

- With slide clamping device at top **part no. 280193/1**
- With slide clamping device lateral **part no. 280193/2**
- Different slide lengths