

STORAGE BOX HOLDER ESD WITH DOUBLE JOINT SWIVEL CANTILEVER

Code: 320516/6

ESD holder for organization boxes with two-link articulated arm allows flexible positioning, fast access, and safe handling of components.

[Link to the product →](#)

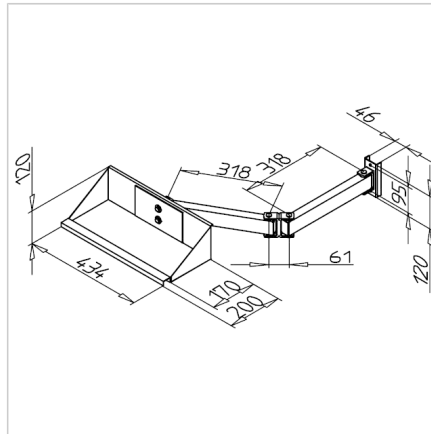

Technical data/items supplied

- Steel, powder-coated, grey
- Fastening material
- Front handle bar
- Load capacity 150 N
- Weight = 4.300 kg/piece

Applications

- As storage area for semi open front containers and semi open front container racks

Assembly

- Installation on the vertical strut of the portal structure