

## TABLE VARIABLE HYDR. HEIGHT ADJUSTABLE STROKE 400

Code: 320171/0

Hydraulically adjustable table with 400 mm stroke for flexible height and efficient production process automation.

[Link to the product →](#)

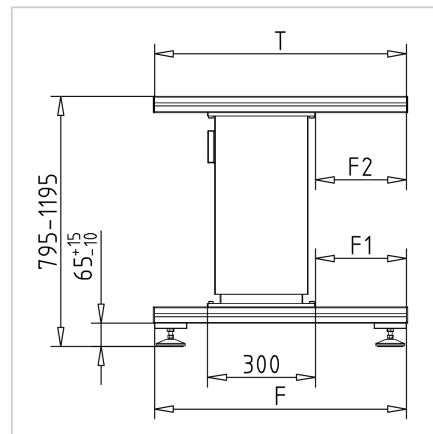
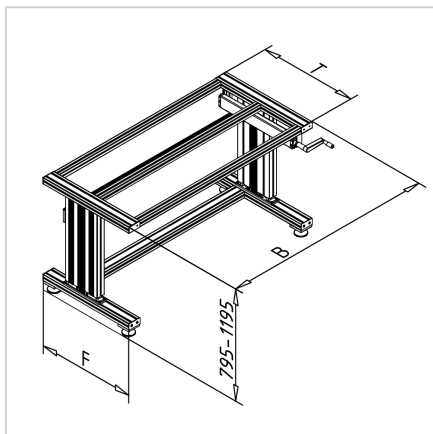

### Technical data/items supplied

- Aluminium, anodized E6/EV1
- Basic frame, profile 45 x 45 F and 45 x 90 F, anodized E6/EV1
- Frame mounted with MiniTec power-lock fasteners
- Feet PA as floor leveling - with spindle M10 and plate Ø80 - height adjustable
- Height adjustment: Hand pump with retractable crank handle, mounted underneath tabletop, synchronous table adjustment with 2 simplex-acting hydraulic cylinders in column sleeves
- up to a level of T 700mm, the hand pump must be mounted on the side.
- Lift speed 5 mm / crank rotation
- **Please specify the required dimensions W, D, F, F1 and F2.**
- Supplied without tabletop and associated mounting bracket
- On request:
  - Higher loads
  - Multiple lift pillars
  - ESD or conductive version