

TIMING BELT REVERSE UNIT T45 Z

Code: 280614/1

Timing belt end piece T45 Z for precise and reliable motion transmission in linear guides.

[Link to the product →](#)

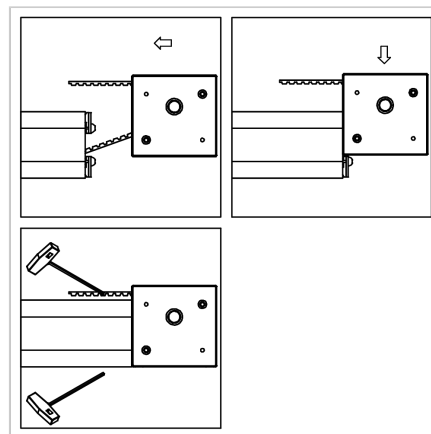
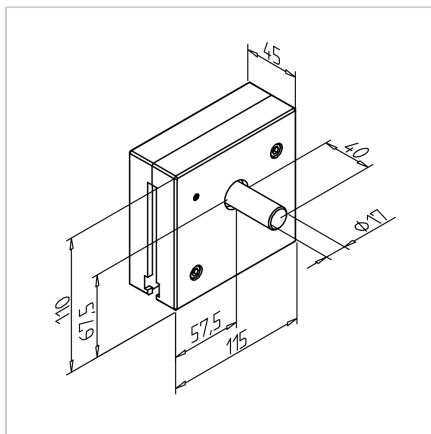

Technical data/items supplied

- Housing 2-piece, anodized aluminum
- Connection elements, steel, galvanised
- Aluminum pulley with stainless steel flanges for timing belt 32AT10 19 teeth, effective diameter 60.48 mm Required toothed belt length within the deflection 210 mm max. torque 70 Nm
- Base body complete with belt pulley and shaft stub
- Drive taps also available in different diameters, lengths and with keyways
- 2 ball-bearings
- **Stainless version part no. 280615/1**
- Weight = 1.369 kg/piece

Applications

- All MiniTec linear guides

Assembly

- Provide rails with thread M8 at both sides, screw in power-lock fastener **part no. 211018/0**
- Guide the timing belt through the reverse unit
- Insert pulley unit from top
- Tighten power-lock fastener
- Tighten the timing belt
- For mounting the corrosion-resistant version, use profile connector H **part no. 211018/1**